

# Onan

## Operator's Manual BGE-BGEL and NHE-NHEL GenSets



### RV Electric Generating Set

(BGE Spec F, BGEL Spec E; NHE Spec D, NHEL Spec D)

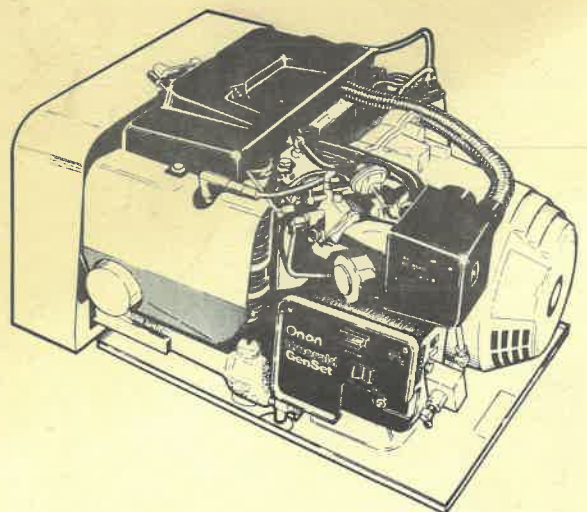

# Safety Precautions

**Before operating the generator set, read the Operator's Manual and become familiar with it and your equipment. Safe and efficient operation can be achieved only if the equipment is properly operated and maintained.** Many accidents are caused by failure to follow fundamental rules and precautions.

The following symbols, found throughout this manual, alert you to potentially dangerous conditions to the operator, service personnel, or the equipment.

**⚠ DANGER** *This symbol warns of immediate hazards which will result in severe personal injury or death.*

**⚠ WARNING** *This symbol refers to a hazard or unsafe practice which can result in severe personal injury or death.*

**⚠ CAUTION** *This symbol refers to a hazard or unsafe practice which can result in personal injury or product or property damage.*

**FUEL AND FUMES ARE FLAMMABLE.** Fire and explosion can result from improper practices.

- DO NOT fill fuel tanks while engine is running. Fuel contact with hot engine or exhaust is a potential fire hazard.
- DO NOT SMOKE OR USE AN OPEN FLAME near the generator set or fuel tank.
- Fuel lines must be adequately secured and free of leaks. Fuel connection at the engine should be made with an approved flexible, non-conductive line. Do not use copper piping on flexible lines as copper will work harden and become brittle.
- Be sure all fuel supplies have a positive shutoff valve.
- DO NOT SMOKE while servicing batteries. Lead acid batteries emit a highly explosive hydrogen gas that can be ignited by electrical arcing or by smoking.

## **EXHAUST GASES ARE DEADLY**

- Never sleep in the vehicle with the generator set running unless vehicle is equipped with an operating carbon monoxide detector.
- Provide an adequate exhaust system to properly expel discharged gases. Inspect exhaust system daily for leaks per the maintenance schedule. Ensure that exhaust manifolds are secure and not warped. Do not use exhaust gases to heat a compartment.
- Be sure the unit is well ventilated.

## **MOVING PARTS CAN CAUSE SEVERE PERSONAL INJURY OR DEATH**

- Before starting work on the generator set, disconnect batteries. This will prevent accidental starting.

- Keep your hands away from moving parts.
- Make sure that fasteners on the generator set are secure. Tighten supports and clamps, keep guards in position over fans, drive belts, etc.
- Do not wear loose clothing near moving parts, or jewelry while working on electrical equipment. Loose clothing and jewelry can become caught in moving parts. Jewelry can short out electrical contacts and cause shock or burning.
- If adjustment *must* be made while the unit is running, use extreme caution around hot manifolds, moving parts, etc.

## **ELECTRICAL SHOCK CAN CAUSE SEVERE PERSONAL INJURY OR DEATH**

- Disconnect starting battery before removing protective shields or touching electrical equipment. Use rubber insulative mats placed on dry wood platforms over floors that are metal or concrete when around electrical equipment. Do not wear damp clothing (particularly wet shoes) or allow skin surfaces to be damp when handling electrical equipment.
- Use extreme caution when working on electrical components. High voltages can cause injury or death.
- Follow all state and local electrical codes. Have all electrical installations performed by a qualified licensed electrician. Tag open switches to avoid accidental closure.
- DO NOT CONNECT GENERATOR SET DIRECTLY TO ANY BUILDING ELECTRICAL SYSTEM. Hazardous voltages can flow from the generator set into the utility line. This creates a potential for electrocution or property damage. Connect only through an approved device and after building main switch is open. Consult an electrician in regard to emergency power use.

## **GENERAL SAFETY PRECAUTIONS**

- Have a fire extinguisher nearby. Maintain extinguisher properly and become familiar with its use. Extinguishers rated ABC by the NFPA are appropriate for all applications. Consult the local fire department for the correct type of extinguisher for various applications.
- Hot coolants under pressure can cause severe personal injury. DO NOT open a radiator pressure cap while the engine is running. Stop the engine and carefully bleed the system pressure.
- Remove all unnecessary grease and oil from the unit. Accumulated grease and oil can cause overheating and engine damage, which presents a potential fire hazard.
- DO NOT store anything in the generator compartment such as oil or gas cans, oily rags, chains, wooden blocks, portable propane cylinders, etc. A fire could result or the generator set operation (cooling, noise and vibration) may be adversely affected. Keep the compartment floor clean and dry.
- Do not work on this equipment when mentally or physically fatigued, or after consuming any alcohol or drug that makes the operation of equipment unsafe.

# Table of Contents

---

TITLE	PAGE
<b>SAFETY PRECAUTIONS</b> .....	Inside Front Cover
<b>INTRODUCTION</b> .....	2
About this Manual .....	2
How to Obtain Service .....	2
<b>SPECIFICATIONS</b> .....	3
<b>OPERATION</b> .....	5
Before Starting .....	5
Recommended Fuels .....	5
Starting and Stopping .....	6
Break-in Procedure .....	6
Operating Conditions .....	6
Generator Set Exercise .....	7
Remote Control (Option) .....	7
Troubleshooting Guide .....	8
<b>MAINTENANCE</b> .....	9
Periodic Maintenance Schedule .....	9
General Inspection .....	10
Exhaust .....	10
Spark Arrester .....	10
Engine Oil .....	10
Battery Care .....	11
Governor Linkage .....	11
Air Filter .....	12
Fuel Filter (LPG Fuel) .....	12
Spark Plugs .....	13
Breaker Points and Condenser .....	14
Lowering and Raising the Under-Floor Mount Set .....	14
Out-of-Service Protection .....	16
Cleaning the Carburetor and Combustion Chamber with Onan "4C" .....	17
Cleaning the Generator Set .....	17
Inspect and Clean Engine .....	17

# Introduction

## ABOUT THIS MANUAL

This manual provides information for operating and maintaining the Onan BGE/NHE (gasoline) and BGEL/NHEL (liquid withdrawal/LPG) models of recreational vehicle generator sets. This manual covers both conventional compartment mount and underfloor mount installations.

Study this manual carefully and observe all warnings and cautions. Using the generator set properly and following a regular maintenance schedule can result in longer unit life, better performance, and safer operation.

## HOW TO OBTAIN SERVICE

When the generator set requires servicing, contact an Onan authorized service center for assistance. Onan factory trained parts and service representatives are ready to handle all service needs. The Parts and Service Center Directory F-115, included with your generator set, lists the Onan representative nearest you. Copies of the warranty (AB-355) and parts catalog are also included in the literature package with your generator set.

When contacting an Onan authorized service center for parts or service, always supply the complete model number and serial number as shown on the Onan nameplate.

Onan		
Model and Spec No.		
Serial No.		
<b>Important</b> Always give above no. s when ordering parts		
AC Volts	Ph	
KVA	kW	
PF	Amps	Hz
DCV	Amps	Watts
RPM	Bat.	
Time Rating		
Insul.-NEMA Class <input type="checkbox"/>	<input type="checkbox"/>	For Recreational Vehicle Use Only
Amb 40°C		Pour Usage Dans Les Vehicules Recreatifs
Onan Corp		Type Fuel: Gasoline
1400 73rd Ave NE		
Minneapolis, MN		
55432 U.S.A.		
Made in USA		99-1360

ONAN NAMEPLATE

# Specifications

	BGE/BGEL		NHE/NHEL	
	50 Hz	60 Hz	50 Hz	60 Hz
<b>GENERAL</b> Weight Control Fuse	204 lb (92.5 kg) 5 Ampere		230 lb (104 kg) 5 Ampere	
<b>ENGINE</b> Oil Capacity (Includes filter) Tune-Up Specifications Spark Plug Gap Breaker Point Gap Fuel Consumption - Gasoline No-load Half-load Full-load Fuel Consumption - LPG No-load Half-load Full-load Speed (r/min)	4 U.S. quarts (3.8 L)  0.025 in. (0.64 mm) 0.016 in. (0.41 mm)  0.35 gal/hr (1.3 L/hr)   0.4 gal/hr (1.5 L/hr) 0.53 gal/hr (2.0 L/hr)   0.6 gal/hr (2.3 L/hr) 0.73 gal/hr (2.8 L/hr)   0.8 gal/hr (3.0 L/hr)  0.4 gal/hr (1.5 L/hr)   0.5 gal/hr (1.9 L/hr) 0.65 gal/hr (2.5 L/hr)   0.8 gal/hr (3.0 L/hr) 0.98 gal/hr (3.7 L/hr)   1.3 gal/hr (4.9 L/hr) 1500   1800		4 U.S. quarts (3.8 L)  0.025 in. (0.64 mm) 0.016 in. (0.41 mm)  0.35 gal/hr (1.3 L/hr)   0.4 gal/hr (1.5 L/hr) 0.57 gal/hr (2.2 L/hr)   0.7 gal/hr (2.5 L/hr) 0.8 gal/hr (3.0 L/hr)   1.3 gal/hr (4.9 L/hr)  0.5 gal/hr (1.9 L/hr)   0.65 gal/hr (2.5 L/hr) 0.78 gal/hr (3.0 L/hr)   1.05 gal/hr (4.0 L/hr) 1.18 gal/hr (4.5 L/hr)   1.70 gal/hr (6.4 L/hr) 1500   1800	
<b>GENERATOR</b> Power (Watts) Voltage Current (Amperes)	3500 110/220 or 120/240 31.8/15.9 or 29.2/14.6	4000 120 33.3	5000 110/220 or 120/240 45.5/22.7 or 41.7/20.8	NHE-6500, NHEL-6300 120 NHE-54.2, NHEL-52.5
<b>BATTERY RECOMMENDATIONS</b> Size Capacity Cranking Current	12 Volts 360 Cold Cranking Amperes 60 Amperes			



# BGE/NHE

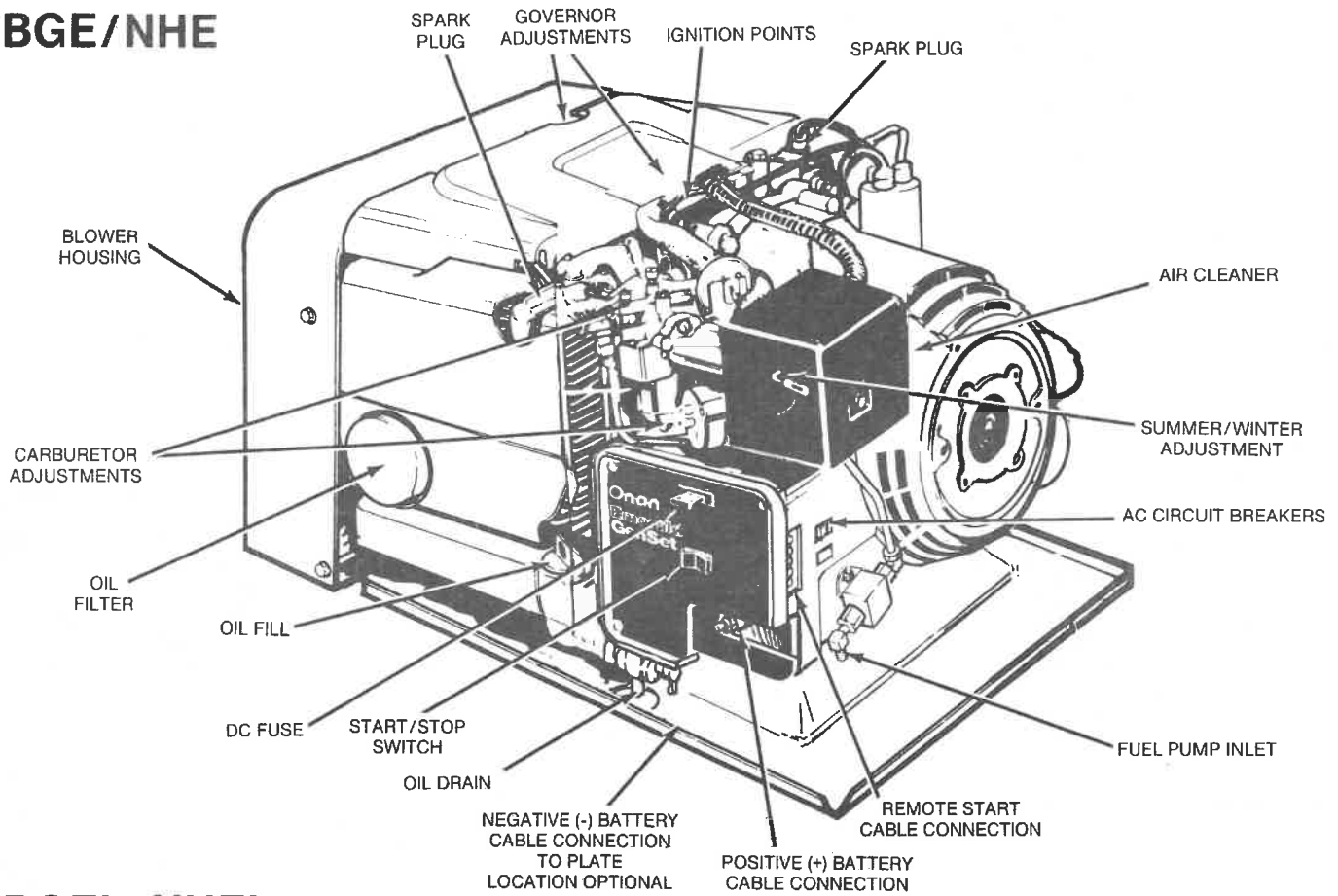

# BGEL/NHEL

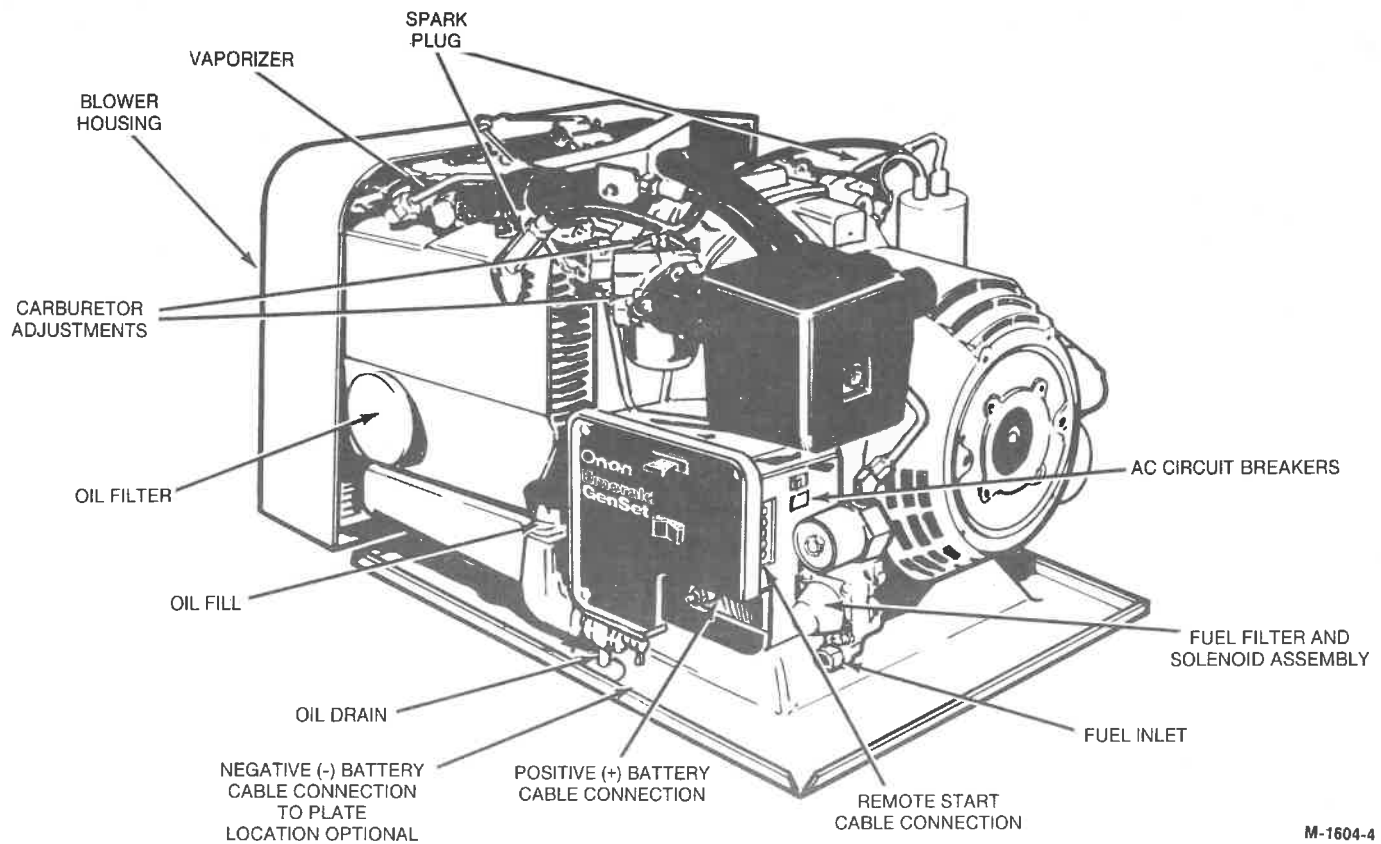

FIGURE 1. TYPICAL EMERALD GENERATOR SETS

M-1604-4

# Operation

---

## ⚠ WARNING

### **EXHAUST GAS IS DEADLY!**

*Exhaust gases contain carbon monoxide, an odorless and colorless gas. Carbon monoxide is poisonous and can cause unconsciousness and death. Symptoms of carbon monoxide poisoning can include:*

- *Dizziness*
- *Nausea*
- *Headache*
- *Weakness and Sleepiness*
- *Throbbing in Temples*
- *Muscular Twitching*
- *Vomiting*
- *Inability to Think Coherently*

**IF YOU OR ANYONE ELSE EXPERIENCE ANY OF THESE SYMPTOMS, GET OUT INTO THE FRESH AIR IMMEDIATELY. If symptoms persist, seek medical attention. Shut down the unit and do not operate until it has been inspected and repaired.**

**Never sleep in vehicle with the generator set running unless the vehicle interior is equipped with an operating carbon monoxide detector. Protection against carbon monoxide inhalation also includes proper exhaust system installation and visual and audible inspection of the complete exhaust system at the start of each generator set operation.**

## BEFORE STARTING

### General Inspection

Before starting, open generator set access panel/door and perform visual inspection of unit and exhaust system. Look for loose or damaged components and fasteners. Correct as necessary.

**⚠ WARNING** *Exhaust gas presents the hazard of severe personal injury or death. Make sure all the exhaust components are operation-worthy and secure.*

Do not start generator set under a load condition. Check that vehicle switching device (if equipped) is at utility position, or vehicle AC distribution panel breakers are off. See Starting and Stopping, this section.

Confirm that vehicle is not parked in high grass or brush.

**⚠ WARNING** *Fire can cause severe personal injury or death. Do not operate the generator set when the vehicle is parked in high grass or brush.*

Do not operate the generator set if exhaust gases will not effectively expel away from vehicle.

**⚠ WARNING** *Exhaust gases can cause severe personal injury or death. Never operate the generator set unless the exhaust system is clear of walls, snow banks, or any obstruction that can prevent exhaust gases from dissipating. Never operate any exhaust fan in the recreational vehicle when the generator set is running. It can cause exhaust gas to be drawn into the vehicle interior.*

### Lubrication

Check the engine oil level. Keep oil level near as possible to the oil fill level indicator FULL mark. Do not overfill. See the *MAINTENANCE* section for procedures.

### Fuel

Make sure the fuel tanks are full. See "Recommended Fuels" following.

**⚠ WARNING** *Fuel presents the hazard of fire or explosion which can result in severe personal injury or death. Do not allow any spark, flame, pilot light, lit cigarette, or any other ignition sources around fuel or fuel system components. Keep a type ABC fire extinguisher nearby.*

## RECOMMENDED FUELS

### Gasoline BGE and NHE Models

Use clean, fresh, unleaded or regular grade gasoline. Using unleaded gasoline results in extended periods between service, longer spark plug life, and reduced carbon clean-out maintenance. If regular gasoline is used, lead deposits must be removed from the cylinder heads as required to reduce engine power loss. Unleaded gasoline can be used safely after regular gasoline usage if lead deposits have been removed from the cylinder head areas.

**⚠ CAUTION** *Alternating between unleaded and leaded (regular) gasoline can result in engine damage unless lead deposits are removed from the cylinder head areas before using unleaded gasoline again.*

## Liquid LPG BGEL and NHEL Models

Use clean, fresh commercial propane or HD-5 grade liquid propane gas in a mixture of at least 90 percent propane. Propane fuels other than HD-5 can contain more than 2.5 percent butane which can result in poor fuel vaporization and poor engine starting in low ambient temperatures (below 32°F or 0°C).

**A manual shutoff valve must be mounted on the propane fuel supply tank. This supply tank valve must be opened fully when operating the generator set to ensure the excess flow valve will close with a broken propane fuel line.**

## STARTING AND STOPPING

The following are general starting and stopping procedures. For initial start-up of unit, refer to Break-in Procedure.

1. Push the start-stop switch to the START position at the generator set control or at remote control (if equipped). Release the switch when the generator set starts.
2. Allow unit to warm up before connecting a load. During warm-up, observe unit operation. Confirm that unit performance is satisfactory.
3. Apply loads. Refer to *SPECIFICATIONS* section for generator set output and performance ratings. Then refer to Figure 2 to aid in determining appliance usage during generator operation.

**CAUTION** *Continuous generator set overloading can cause high operating temperatures that can damage the generator windings. Keep the load within the nameplate rating.*

Appliance or Tool	Approximate Running Wattage
Refrigerator . . . . .	600-1000
Electric broom . . . . .	200-500
Coffee percolator . . . . .	550-700
Electric frying pan . . . . .	1000-1350
Hair dryer . . . . .	800-1500
Electric stove (per element) . . . . .	350-1000
Electric iron . . . . .	500-1200
Radio . . . . .	50-200
Electric water heater . . . . .	1000-1500
Space heater . . . . .	1000-1500
Electric blanket . . . . .	50-200
Television . . . . .	200-600
Electric drill . . . . .	250-750
Battery charger . . . . .	Up to 800
Air conditioner . . . . .	1400-2000
Converter . . . . .	300-500
Microwave oven . . . . .	700-1500

FIGURE 2. APPROXIMATE POWER REQUIREMENTS OF COMMON APPLIANCES

4. To stop generator set, remove all loads and allow unit to run for three to five minutes to cool down. Then push the start-stop switch to the STOP position at the generator set control or at remote control.

## BREAK-IN PROCEDURE

To prevent high oil consumption or glazing of the engine cylinders, Onan recommends breaking-in of the unit. The procedure is as follows:

1. After starting, plug in enough appliances to total one-half the generator set capacity (about 2,000 watts for BGE and BGEL; about 3000 watts for NHE and NHEL). Refer to Figure 2 for the approximate wattages of common appliances.
2. Run the generator set with this load for two hours.
3. Operate the generator set at three-quarters capacity for another two hours. Refer to Figure 2.

**These loads are approximations. If you do not have enough appliances in the vehicle for three-quarters capacity, engage as many appliances as you can.**

4. Change the engine crankcase oil after the 50 hours of operation and every 150 hours after that. See *MAINTENANCE* section.

## OPERATING CONDITIONS

### Hot Weather

In hot weather (above 90°F/33°C), keep the cooling fins clean and see that nothing obstructs airflow to and from the generator set.

### Cold Weather

Use the correct oil weight and type for cold weather conditions. See the *MAINTENANCE* section. Change the oil only when the engine is warm. If sudden temperature variations occur and your current oil is not the appropriate viscosity, change the oil following the recommendations.

**BGE and NHE (Gasoline) Models Only:** At temperatures below 40°F (4°C), move the carburetor air preheater lever to the WINTER position. The actuating lever is located on the outside of the air cleaner housing (see Figure 7). At temperatures above 70°F (21°C), move the preheater lever to the SUMMER position. Between 40°F (4°C) and 70°F (21°C), you can leave the preheater in either position.

**CAUTION** *Operation of the preheater when temperatures are above 70°F (21°) can cause erratic operation and can result in reduced engine power and reduced engine life.*

### High Altitudes

Maximum power will be reduced about four percent for each 1000 feet (310 m) above sea level after the first 1000 feet (310 m). If operation is inhibited by high altitude (above 2000 feet or 620 m), adjust the carburetor main fuel adjustment for a slightly leaner fuel mixture. Turn the main fuel adjustment in 1/8 turn. See Figure 3.

**CAUTION** *When determining fuel mixture settings, never force the fuel mixture adjustment needles against their seats. This damages the seats and the needles.*



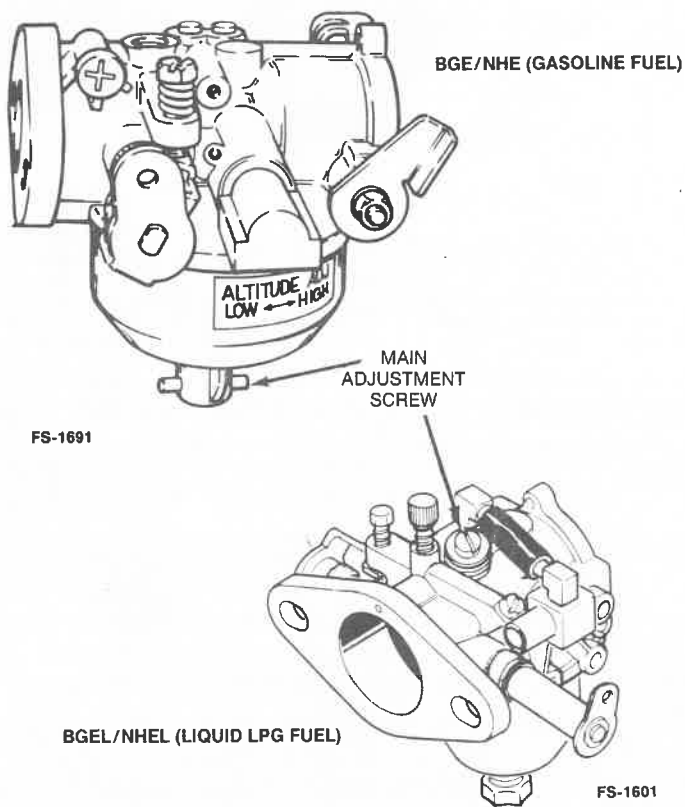

FIGURE 3. CARBURETOR MAIN ADJUSTMENT SCREW

### Extremely Dusty or Dirty Conditions

1. Keep the generator set clean. Keep cooling surfaces clean.
2. Service the air cleaner as frequently as necessary.
3. Change the engine crankcase oil every 50 operating hours.
4. Keep oil in dust-tight containers.
5. Keep the governor linkage clean. The *MAINTENANCE* section shows this procedure.

### GENERATOR SET EXERCISE

Infrequent use can result in difficult starting and moisture condensation in the engine. Moisture is caused by the engine not running enough to reach normal operating temperature. If severe enough engine damage can result.

During infrequent use, guard against engine damage. Run the generator set at 50 percent capacity (BGE/BGEL: 2000 watts; NHE/NHEL: 3000 watts; or one air conditioner) for two hours every four weeks. Exercising for longer time periods is better than several short intervals.

### REMOTE CONTROL

Optional remote start-stop controls are available for all Onan recreational vehicle generator sets. The remote control allows you to operate your generator set from inside your motor home.

The Standard remote control includes a start-stop switch, and an indicator lamp that illuminates when the unit is operating. The Deluxe control contains these items plus a running time meter and a battery condition meter. See Figure 4.

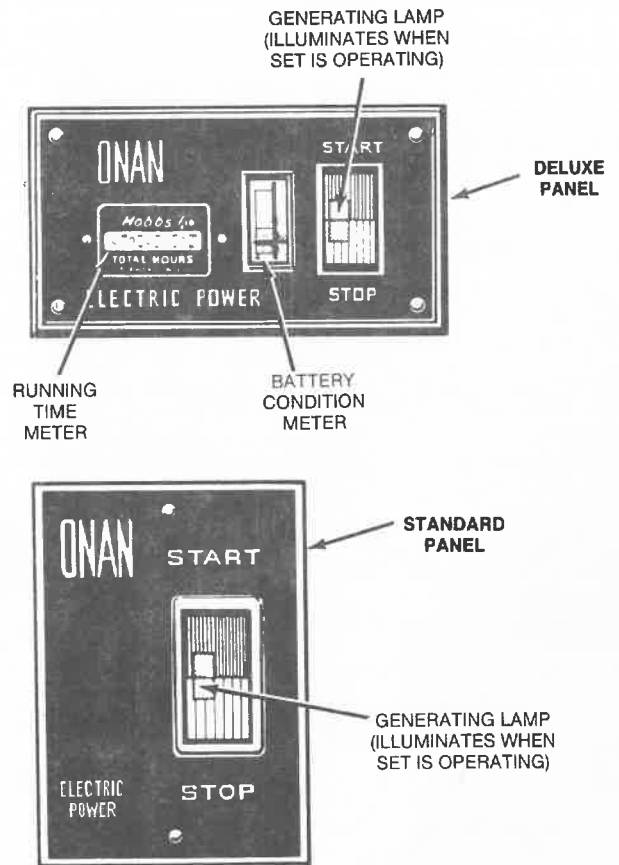

FIGURE 4. REMOTE CONTROL PANELS

### Using the Remote Control

Depress the start-stop switch to the START position and hold until the light illuminates (this indicates that the generator set is operating), then release the switch. See Figure 4.

If you held the switch at START position for ten seconds and the light does not illuminate, release the switch. Wait two minutes and try again. If the second attempt does not start the generator set, start the unit at the set control. Failure of the light to illuminate may indicate an open circuit in the remote wiring. Contact an Onan dealer for assistance.

The running time meter indicates cumulative total hours of generator set use. Record hours indicated each time unit maintenance is performed.

The battery condition meter indicates the relative condition of the battery, and battery charging circuit. The meter should remain in the normal zone. If meter reading is consistently high or low, contact an Onan dealer for assistance.

## TROUBLESHOOTING GUIDE

The following is a simplified troubleshooting guide. If these recommendations fail to resolve the problem, contact your Onan service organization generator set repair service.

Problem	Probable Cause	Solution
FAILS TO CRANK	<ol style="list-style-type: none"> <li>1. Low battery.</li> <li>2. Bad battery connection.</li> <li>3. Blown fuse.</li> </ol>	<ol style="list-style-type: none"> <li>1. Check battery electrolyte level.</li> <li>2. Clean and tighten all battery and cable connections.</li> <li>3. Replace fuse on control box. See specifications for proper fuse rating.</li> </ol>
CRANKS SLOWLY	<ol style="list-style-type: none"> <li>1. Low battery.</li> <li>2. Bad battery connection.</li> <li>3. Oil is too heavy.</li> <li>4. Load connected.</li> </ol>	<ol style="list-style-type: none"> <li>1. See "Fails to Crank", #1.</li> <li>2. See "Fails to Crank", #2.</li> <li>3. Replace with lighter oil.</li> <li>4. Remove load.</li> </ol>
CRANKS BUT WON'T START	<ol style="list-style-type: none"> <li>1. Fuel below genset pick-up level in tank.</li> <li>2. Fuel supply shutoff valve closed.</li> <li>3. Carbon deposits on spark plugs.</li> </ol>	<ol style="list-style-type: none"> <li>1. Add fuel.</li> <li>2. Fully open fuel supply valve.</li> <li>3. Remove spark plugs and clean.</li> </ol>
EXHAUSTING BLACK SMOKE	<ol style="list-style-type: none"> <li>1. Rich fuel mixture</li> <li>2. Dirty air filter.</li> <li>3. Excess oil.</li> </ol>	<ol style="list-style-type: none"> <li>1. Turn main fuel adjustment in 1/8 turn (location of adjustment is shown in Figure 3).</li> <li>2. Replace air filter.</li> <li>3. Reduce engine oil level.</li> </ol>
UNIT RUNS THEN STOPS	<ol style="list-style-type: none"> <li>1. Out of fuel.</li> <li>2. Low oil level.</li> <li>3. Excess oil.</li> </ol>	<ol style="list-style-type: none"> <li>1. Refill fuel tank.</li> <li>2. Add oil if necessary.</li> <li>3. Reduce engine oil level.</li> </ol>
UNIT RUNS BUT SURGES	<ol style="list-style-type: none"> <li>1. Worn breaker points.</li> <li>2. Loose or worn spark plug leads.</li> <li>3. Ignition coil, wiring, or control components defective.</li> </ol>	<ol style="list-style-type: none"> <li>1. Adjust or replace breaker points.</li> <li>2. Check security of spark plug leads at spark plugs and ignition coil. Replace leads if worn.</li> <li>3. Contact an Onan representative.</li> </ol>

**▲WARNING** *A hot generator set can cause severe burns. Always allow the generator set to cool before performing any maintenance or service.*

# Maintenance

Establish and adhere to a definite schedule for maintenance and service. If the generator set is subjected to extreme operating conditions, you should reduce the intervals accordingly.

Consult your Onan dealer if the generator set will be subjected to any extreme operating conditions and determine a suitable maintenance schedule. Keep an accurate log of all service and maintenance performed for warranty support.

Perform all the maintenance at the time period indicated or after the number of operating hours indicated, whichever comes first. Use the schedule to determine the maintenance required, and then refer to the sections that follow for the correct procedures.

If you have the under-floor mount generator set and it must be lowered for any maintenance procedure (that is, you cannot service it in its normal position), see the procedure "Lowering the Under-Floor mount Generator Set" in this section before beginning the maintenance procedure.

**⚠ WARNING** *Accidental starting of the generator set during maintenance procedures can cause severe personal injury or death. Disconnect both generator set starting battery cables before performing maintenance; disconnect negative (-) cable first.*

## PERIODIC MAINTENANCE SCHEDULE

Service These Items	After Each Cycle of Indicated Hours				
	8	50	150	200	300
General Inspection	x <sup>1</sup>				
Check Oil Level	x				
Check Battery Electrolyte Level		x			
Clean Out Spark Arrester		x			
Clean and Lubricate Governor Linkage		x			
Change Crankcase Oil and Oil Filter			x <sup>2,7</sup>		
Change Air Filter			x <sup>2</sup>		
Clean Fuel Filter			x <sup>3</sup>		
Replace Spark Plugs			x <sup>4,9</sup>		
Check Breaker Points			x <sup>5</sup>		
Replace Breaker Points				x <sup>4,9</sup>	
Clean Cooling Fins				x <sup>6</sup>	
Clean Carburetor and Combustion Chamber with Onan "4C" Cleaner			x		
Clean Generator Set			x		
Inspect and Clean Engine					x <sup>6</sup>
Adjust Carburetor			As Required <sup>6</sup>		
Check Generator Brushes			As Required <sup>6</sup>		
Exercise Generator Set			As Required <sup>8</sup>		

- <sup>1</sup> - With set running, visually and audibly check exhaust system for leaks.
- <sup>2</sup> - Every 150 operating hours or once a year, whichever is first. Perform more often in extremely dusty conditions (i.e., check monthly, and change if dirty).
- <sup>3</sup> - Equipped on BGEL and NHEL models. Customer option for BGE and NHE models.
- <sup>4</sup> - Or replace annually, or prior to storage, whichever is first.
- <sup>5</sup> - Replace if necessary.
- <sup>6</sup> - Have your Onan service center perform.
- <sup>7</sup> - First oil change during first year or 50 hours of operation, whichever is first.
- <sup>8</sup> - During periods of nonuse, exercise for 2 hours every 4 weeks.
- <sup>9</sup> - Refer to Out-of-Service Protection if unit is to be stored.

## GENERAL INSPECTION

Perform a general inspection every eight operating hours. Start the generator set. Visually and audibly check for abnormalities.

## EXHAUST

Examine the exhaust system for leaks. If you have a conventional compartment mount generator set, inspect the compartment for holes which might allow exhaust gas to enter the recreational vehicle. Do NOT operate the generator set if it runs louder than usual, the compartment has holes to the interior, or the exhaust system has leaks. See your Onan service center as soon as possible and do not operate the generator set until the problem has been corrected.

**⚠ WARNING** *Exhaust gas presents the hazard of severe personal injury or death. If you find any exhaust leaks, do not operate the generator set and have the exhaust system repaired as soon as possible.*

## SPARK ARRESTER

Exhaust spark arresters are necessary for SAFE OPERATION. All require periodic clean-out to maintain maximum efficiency. See the maintenance schedule for recommended cleaning intervals.

To clean the spark arrester, remove the 1/8 inch pipe plug from the bottom of the muffler. Run the generator set with load for five minutes. Stop the generator set and allow the muffler to cool. Replace the pipe plug in the muffler.

## ENGINE OIL

### Checking Engine Oil Level

Be sure the engine crankcase is filled with oil to the FULL mark on the oil level indicator (Figure 5). When adding oil between changes, use the same brand. Different brands might not be compatible when mixed. See "Recommended Engine Oil" in this section.

Add oil until it reaches the FULL mark on the oil level indicator, but do NOT overfill. Too much oil can cause foaming and engine shutdown. Always replace the oil level indicator tightly to avoid leakage.

**⚠ WARNING** *Hot oil can cause severe personal injury. Do not check the oil level with the generator set running. Oil can blow out the oil fill.*

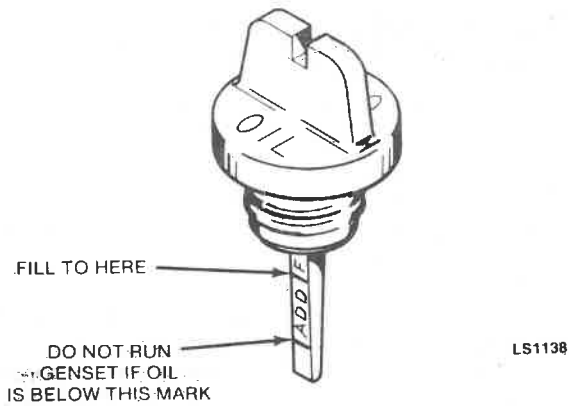

FIGURE 5. OIL LEVEL INDICATOR

Check the oil level as follows:

1. Remove oil level indicator and wipe with clean rag.
2. Reinstall oil level indicator to normal operating position (fully in).
3. Unscrew indicator out again and check oil level on indicator stem.
4. Add oil as prescribed above.

### Changing Engine Oil and Oil Filter

Figure 1 shows the location of the oil drain, oil filter, and oil level indicator. If operating in dusty or dirty conditions, change the oil more frequently than shown in the maintenance schedule.

To drain oil, place a pan under the oil drain valve. Open valve and allow oil to drain from engine. Close drain valve.

Use only Onan approved oil filters. Onan filters are application-tested for reliable service. To change the filter, place a pan under the filter and turn counter-clockwise. Coat the new oil filter gasket lightly with engine oil and install. Turn clockwise until the gasket just touches the oil filter mounting base, then tighten an additional half turn. Wipe up any excess oil.

Refer to SPECIFICATIONS section for oil capacity. Also see the following Recommended Engine Oil to select proper grade of oil. Remove oil level indicator. Replenish oil into engine at fill port.

Replace oil level indicator to normal operating position (fully in). Tighten securely to avoid leakage. Wipe clean any excess oil and properly dispose of cleaning rags and old oil.

## Recommended Engine Oil

Use oil with the API (American Petroleum Institute) designation SF. Oil should be labeled as having passed MS Sequence Tests (also known as having passed ASTMG-1V Sequence Tests). Refer to the oil chart (Figure 6) for recommended viscosity and temperatures.

Oil consumption can be higher with a multigrade oil than with a single grade oil if both oils have a comparable viscosities at 210°F (99°C). For that reason, single grade oils are generally desirable unless anticipating a wide range of temperatures.

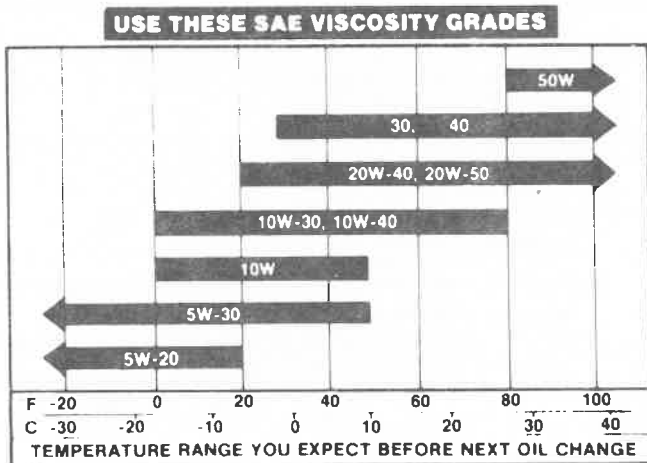

LS1139

FIGURE 6. SAE VISCOSITY GRADES

## BATTERY CARE

To increase battery life, the operator can perform a number of routine checks and some preventive measures.

1. Keep the battery case clean and dry.
2. Make sure the battery cable connections are clean and tight. Use a terminal puller when removing cables.
3. Identify each battery cable to be positive or negative before making any connections. Always connect the ground (negative) cable last.
4. Maintain the electrolyte level by adding water (drinking quality or better) as needed for filling to the split-level marker in the battery.

The water ingredient of the electrolyte evaporates, but the sulphuric acid ingredient remains. For this reason, add water, not electrolyte.

5. Avoid overcharging when recharging. Stop the boost charge when the electrolyte specific gravity is 1.260 at about 80°F (27°C).

**⚠ WARNING** Batteries present the hazard of explosion which can result in severe personal injury. Do not smoke or allow any arc-producing devices around the battery area. Do not disconnect battery cables while the generator set is cranking or running. Batteries give off explosive gases.

## GOVERNOR LINKAGE

The governor linkage must be free to move through its entire travel. Clean and lubricate as specified in the maintenance schedule. Refer to Figure 7.

The nylon joint is self-lubricating and requires no additional lubricant. To clean, simply wipe joint with a dry cloth. Refer to "A" of Figure 7.

**⚠ CAUTION** Some lubricants have solvents that can damage the governor nylon joint. Read the manufacturer's instructions before using.

For the steel governor joint, "B" of Figure 7, lubricate the joint with graphite.

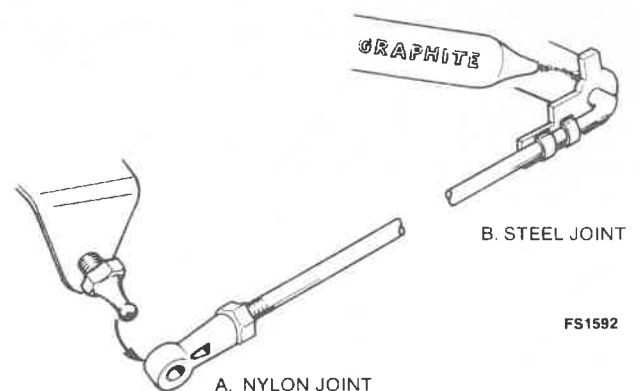

FS1592

FIGURE 7. LINKAGE CLEANING AND LUBRICATION

## AIR FILTER

In dusty conditions, change the air filter often (Figure 8). Onan air filters are treated with a fire retardant to prevent fire caused by engine backfire. Use only Onan approved filters. Universal filters look similar but might not perform to Onan and certified agency specifications. Onan filters are application-tested for reliable service.

To change the filter, remove the through-bolt on the outside of the air cleaner housing (Figure 8).

**CAUTION** For BGE and NHE models only (gasoline), when removing the air cleaner housing, be careful not to damage the carburetor air preheater hose which is attached to the housing.

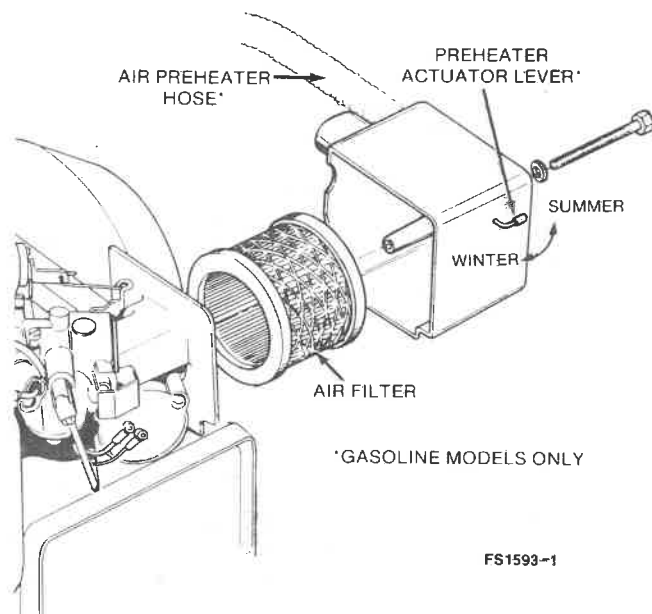

FIGURE 8. REPLACING THE AIR FILTER

## FUEL FILTER (BGE AND NHE-LPG FUEL)

The fuel filter (see Figure 9) removes solid impurities such as rust or scale from the LP-gas before they can clog the regulator or carburetor. A magnet within the filter housing traps iron or rust particles while a filter element traps non-magnet particles. The fuel filter operates at container pressure and must be carefully assembled after filter cleaning to prevent leakage.

To perform maintenance on the liquid LPG fuel filter, first purge the fuel system as described.

## Purging Fuel System

1. Close the shutoff valve at the fuel tank.
2. Start the generator set and run until it runs out of fuel.
3. Crank engine a few times after it stops to make sure it is completely purged of fuel.
4. Move the recreational vehicle to a location that is well-ventilated and away from any spark, pilot light, lit cigarette, fire, flame, or other ignition source.
5. Remove the vehicle negative (-) battery ground cable and the generator set negative (-) ground cable from their respective batteries.
6. Close the fuel shutoff valves at the fuel tank for both the generator set fuel supply system and the appliance (stove, heater, etc.) fuel supply system. In addition, close the fuel shutoff valves at each appliance.

**WARNING** Liquid LP gas presents the hazard of fire or explosion which can result in severe personal injury or death. Eliminate all sources of ignition such as lit cigarettes, flames, pilot lights and sparking electrical equipment before purging the fuel system. Provide adequate ventilation to dissipate LP gas as it is released.

7. Slightly open the flexible section of fuel line at the solenoid valve just enough to allow the gas to escape slowly.
8. Disconnect the fuel supply hose from the carburetor and hold it clear of the set.
9. Press in and hold the primer button on the regulator to release LP gas from the set fuel system. When no more gas can be heard escaping from the open end of the fuel supply hose, reconnect the hose to the carburetor and proceed to "Cleaning Liquid LPG Fuel Filter."



## Cleaning Liquid LPG Fuel Filter

Clean the LPG filter using the following procedure. Refer to Figure 9.

1. Remove the four capscrews and lock washers that secure the filter bowl to the filter body.
2. Separate filter bowl from filter body and discard the O-ring seal.
3. Remove nut and washer from center stud and pull out the filter element.
4. If filter element is clogged, wash element in kerosene and blow dry with low pressure (30 psi or 207 kPa) compressed air. Replace filter element if damaged.

**▲WARNING** *Kerosene presents the hazard of fire or explosion which can cause severe personal injury or death. Do not expose the kerosene to flame, pilot light, lit cigarette or any arc-producing device. Clean with care.*

5. Wipe the center stud magnet clean of any rust or scale particles that have collected. Do not tap the magnet clean of loose particles; magnet may become damaged.
6. Install clean filter element using new gaskets (2) and securely tighten center and stud nut.
7. Place a new O-ring in the filter bowl sealing groove.

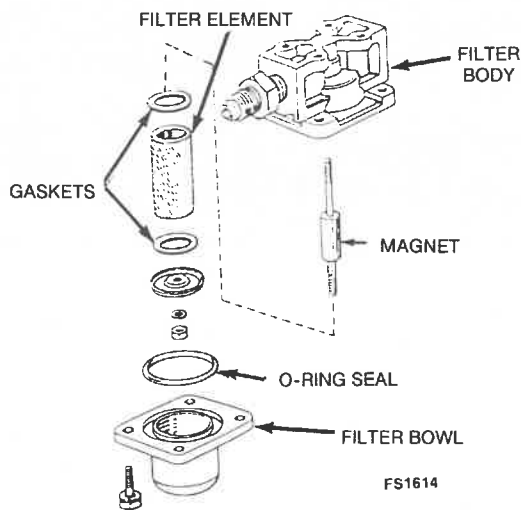

FIGURE 9. LIQUID LPG FUEL FILTER

8. Align reference mark on the filter bowl with reference mark on filter body and install capscrews (4). Tighten capscrews 56 to 74 in. lb. (6.5 to 8.3 N•m) torque. When the fuel system is pressurized, check filter for leaks.

**▲WARNING** *Liquid LPG presents the hazard of fire or explosion which can result in severe personal injury or death. After assembly of the filter assembly and turning on the fuel shutoff valve, check to make sure the filter does not leak using a soap and water solution. If it leaks, turn off the shutoff valve immediately. If you cannot determine source, call your nearest Onan service center.*

## SPARK PLUGS

A spark plug with heavy combustion deposits can cause misfiring, poor operation, or stopping when a load is applied. Each time the spark plugs are removed, inspect, and regap (Figure 10). If a plug looks discolored or fouled, replace it.

- Black deposits indicate a rich mixture.
- Wet plug indicates misfiring (gasoline fuel only).
- Badly or frequently fouled plug indicates the need for a major tune-up.

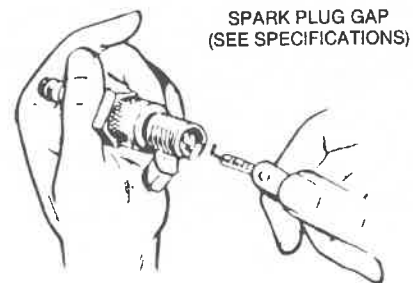

FIGURE 10. MEASURING PLUG GAP

## BREAKER POINTS AND CONDENSER

It is important that the breaker points and condenser be in good working condition, and the breaker points properly adjusted for efficient generator set operation.

The condenser extends the breaker point service life by preventing arcing across the points as they open and close. A defective condenser causes a weak spark at the spark plugs and rapid point wear produced by arcing across the points.

If the breaker points are pitted or burned or the condenser is suspected as defective, replace both by obtaining a tune-up kit from an Onan dealer.

Use the following procedure to replace and adjust the breaker points and condenser.

Ignition adjustments should be made with the engine stopped and allowed to cool down.

1. Disconnect the negative (-) battery cable at the battery terminal.
2. The breaker points and condenser mount on top of the engine block. Remove the breaker box cover clip and lift off the breaker box cover.
3. Remove the spark plugs to permit easy rotation of the engine and generator assembly. Using a 3/8 inch hex socket driver and socket wrench, turn the rotor through-bolt in a clockwise direction until the breaker point gap is open the maximum amount.
4. Remove the condenser mounting screw (A) and disconnect the condenser and ignition lead wires (screw B). Lift out condenser (see Figure 11).

Condenser might be mounted outside breaker points box on engine adapter flange or generator housing.

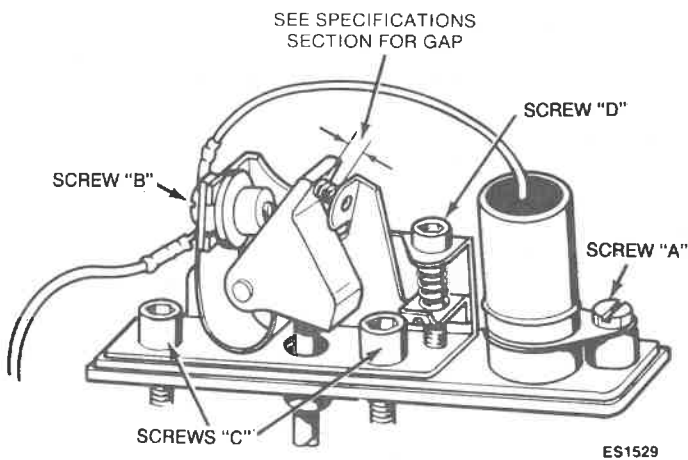

FIGURE 11. SETTING BREAKER POINTS

5. Remove the breaker points mounting screws (C) and lift out the point assembly.
6. Replace the condenser and point assembly and install in reverse order of removal.
7. Use an allen head wrench to adjust set screw D to obtain the gap setting specified in the Specifications section. Measure the point gap with a flat thickness gauge (see Figure 11).

Make sure feeler gauge is clean and free of any grease, oil or dirt.

The timing is adjusted during initial engine assembly and is fixed by the point gap adjustment. No other adjustment or alignment is necessary.

8. Replace the breaker point box cover and hold-down wire, spark plugs, and spark plug leads.
9. Connect negative (-) battery cable to negative battery terminal.

## LOWERING AND RAISING THE UNDER-FLOOR MOUNT SET

If the under-floor mount generator set model must be lowered for maintenance or service (that is, it cannot be serviced in its normal position), use these procedures, following the instructions very carefully.

A floor jack is required to safely lower and raise the generator set. See Figure 12.

**WARNING** *The generator set falling can cause severe personal injury or death and equipment damage. Use a floor jack or other such device to control and support the weight of generator set when lowering and raising the unit. Do not attempt to lower or raise the generator set by hand.*

If generator set will be left in the down (tilted) position for more than thirty minutes, first drain the oil.

**CAUTION** *Oil in the engine cylinders can cause engine damage during starting attempts. Because oil can enter the engine cylinders when the generator set is lowered (tilted), do not leave the generator set in the lowered position for more than thirty minutes if the oil has not been drained.*

### Lowering Under-Floor Generator Set

1. Park the recreational vehicle on as level a surface as possible.
2. Put the vehicle in its park position, lock the brakes, and remove the ignition key. Make sure no one moves the vehicle while performing this procedure.

**⚠WARNING** *Dropping the generator set creates the hazard of serious personal injury or death. Make sure that no one moves the vehicle during this procedure and that the procedure is performed very carefully and only as indicated.*

3. Disconnect both battery cables, negative (-) cable first, at the generator set starting battery and open the generator set access door (if any).
4. If the generator set exhaust system is connected to or supported by the under-structure of the recreational vehicle, you will have to separate the exhaust system near the generator set before lowering the unit.
5. Check the electrical connections and fuel line to the generator set to make sure there is sufficient slack when lowering the generator set.

**⚠WARNING** *Fuel presents the hazard of fire or explosion which can result in severe personal injury or death. Do not allow any spark, flame, pilot light, lit cigarette, or any other ignition sources around fuel or fuel system components. Keep a type ABC fire extinguisher nearby.*

6. Use a floor jack similar to the one shown in Figure 12, and position the floor jack under the reinforcement ribs of the drip tray as shown.

Use an adequate floor jack. Refer to **SPECIFICATIONS** section for unit weight.

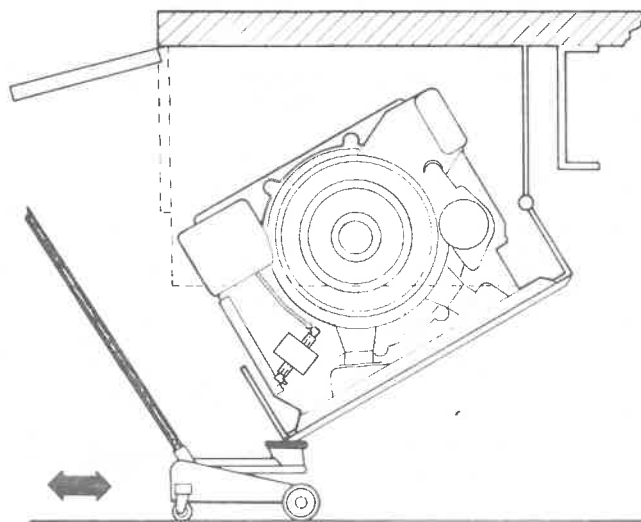

**⚠WARNING** *The generator set falling can cause severe personal injury or death and equipment damage. Use a floor jack or other such device to control and support the weight of generator set when lowering. Do not attempt to lower generator by hand.*

7. Raise the floor jack until it just makes contact with the drip tray, then just put a little upward pressure under the drip tray.
8. Remove the bolts from the front and rear (NHE only) support bracket(s), and remove the support bracket(s). This might require slight adjustment of the floor jack, either slight raising or lowering of the jack.
9. Once the support bracket is removed, all the weight of the generator set on that side is on the floor jack. Slowly lower the floor jack, being careful to allow the floor jack to roll as the generator set swings downward.

**⚠WARNING** *The generator set falling can cause severe personal injury or death. Make sure the generator set is resting securely before moving the floor jack.*

10. Onan suggests you put some wood blocks under the drip tray assembly so that you can remove the floor jack. This will allow you more access room for the maintenance or service procedure.
11. Perform maintenance or service procedures.

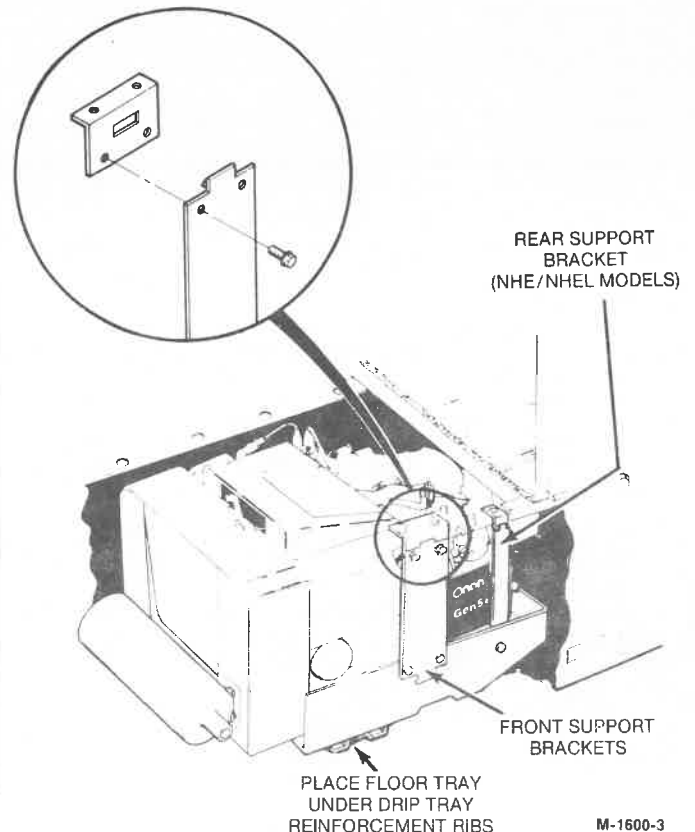

FIGURE 12. LOWERING UNDER-FLOOR MOUNT GENERATOR SET

## Raising Under-Floor Generator Set

1. Reposition the floor jack under the reinforcement ribs of the drip tray. Before raising the generator set, make sure you will not damage any electrical connections, the fuel line, etc.
2. Slowly lift up the generator set.

Use an adequate floor jack. Refer to **SPECIFICATIONS** section for unit weight.

**▲WARNING** *The generator set falling can cause severe personal injury or death and equipment damage. Use a floor jack or other such device to control and support the weight of generator set when lifting. Do not attempt to lift generator by hand.*

3. When the generator set reaches the upward limit, re-install the support bracket. You might have to make a slight adjustment with the floor jack, with slight raising or lowering of the jack to engage the safety support bracket hooks (on end of panel ends).
4. Use Loctite or similar thread locking material on the bolts used to secure the support bracket in place (ones removed from Step 8 of "Lowering Under-Floor Generator Sets"). Then install the 5/16-inch bolts to 14 ft-lb (19 N•m).
5. Fasten or secure any fuel line, and exhaust components moved or disconnected for this procedure. Make sure the exhaust components are put back in their original positions.

**▲WARNING** *Exhaust gas presents the hazard of severe personal injury or death. Make sure all components are reinstalled in their original places and that the exhaust system is operation-worthy to prevent any exhaust leaks.*

6. Fasten battery cables at generator set terminals, if disconnected for this procedure.
7. Reconnect the generator set battery cables at the battery; first the positive (+) lead, then the negative (-) ground lead last.
8. If engine oil was drained for maintenance, refer to Engine Oil and replenish as necessary.
9. Close the access door (if any). The generator set should now be ready for operation.

## OUT-OF-SERVICE PROTECTION

If you are unable to exercise the generator set regularly and your set will not be in use for more than 30 days, the following procedure is recommended.

### Preparing Generator Set for Storage

1. Run the generator set at 50 percent capacity for one hour.
2. Turn off the fuel supply and remove the air filter. As the generator set runs out of fuel, squirt defogger into the carburetor intake and reassemble air filter.
3. Shut the generator set off. Remove the spark plugs. Pour one tablespoon (about 30 ml) of standard engine oil into the spark plug holes. Crank the engine for about 10 seconds. Replace the spark plugs.
4. Change the oil when the exhaust system has cooled.
5. Disconnect cables from starting battery; negative (-) cable first.

### Returning Generator Set to Operation

1. Perform a general inspection of the generator set.
2. Check battery electrolyte level, and reconnect cables; negative (-) cable last.
3. Check air filter. Replace if dirty.
4. Check the engine oil level.
5. Open (turn on) fuel supply.
6. Start the generator set at the unit. Initial start-up might be slow due to oil in the cylinders. Smoke and rough operation will occur until the oil in the cylinders is burned. If it fails to start, replace the spark plugs.
7. Apply 50 percent load to the generator set until it runs smoothly. Let it run for an hour.
8. Remove load and let the generator set run for three to five minutes to cool down. Then push the start-stop switch to STOP position. The generator set is now ready for operation.

## CLEANING THE CARBURETOR AND COMBUSTION CHAMBER WITH ONAN "4C"

### **▲WARNING**

*Inhalation of chemical sprays can cause severe personal injury or death.*

*Use safety goggles to protect eyes and a respirator or painter's mask to prevent inhaling any chemical that may spit back from the carburetor during this procedure. Also, work in a well-ventilated area to avoid other personnel from inhaling any fumes.*

### **▲WARNING**

*Fumes from this cleaner presents the hazard of fire or explosion, which can cause severe personal injury or death. Do not allow any spark, flame, pilot light, lit cigarette, or other ignition source near generator set when performing this procedure. Keep a fire extinguisher rated ABC near work area.*

Perform the following as indicated on the maintenance schedule to help keep the carburetor and intake manifold clean, and carbon deposits from forming in the combustion chamber. If you experience engine pinging or power loss, consult your Onan representative.

1. Start the generator set and allow it to warm up to normal operating temperature.
2. Stop generator set.
3. Remove the air cleaner housing and air filter.
4. Restart the generator set, and spray the contents into the carburetor, redirecting the spray to wash the choke plate and inside walls. Spray as much as possible into the carburetor without stalling the engine. The spray enters the combustion chamber and softens the carbon, allowing it to flake off and exit through the exhaust pipe. When you have about an ounce of the chemical remaining in the can, flood the engine until it dies.

5. Leave the engine off for 15 minutes while the product continues to soften the carbon.
6. Restart the engine, with all electrical appliances off. Gradually increase the load on the generator set by turning on the appliances. Once the generator set is under full load, let it run for a few minutes to blow out the carbon.

## CLEANING THE GENERATOR SET

The generator set should be cleaned every six months or sooner if severe road contamination or dusty conditions are encountered. Dust usually can be removed with a damp cloth. Some road contaminants however, may require steam for removal. Do not steam clean the generator set while the engine is running. When cleaning, provide cover or protection so spray is not directed into the generator, air cleaner, control box, fuel solenoid, or electrical connectors. Do not clean with solvents; they can damage electrical connectors.

## INSPECT AND CLEAN ENGINE (INTERNAL)

Low-load unit operation (less than 50 percent rated), additives and impurities in fuel used, and varied operating conditions can adversely effect engine performance and cause parts to wear. The engine combustion chamber should be inspected for possible component wear and carbon buildup after approximately 300 hours of use. See maintenance schedule, have Onan service representative perform.

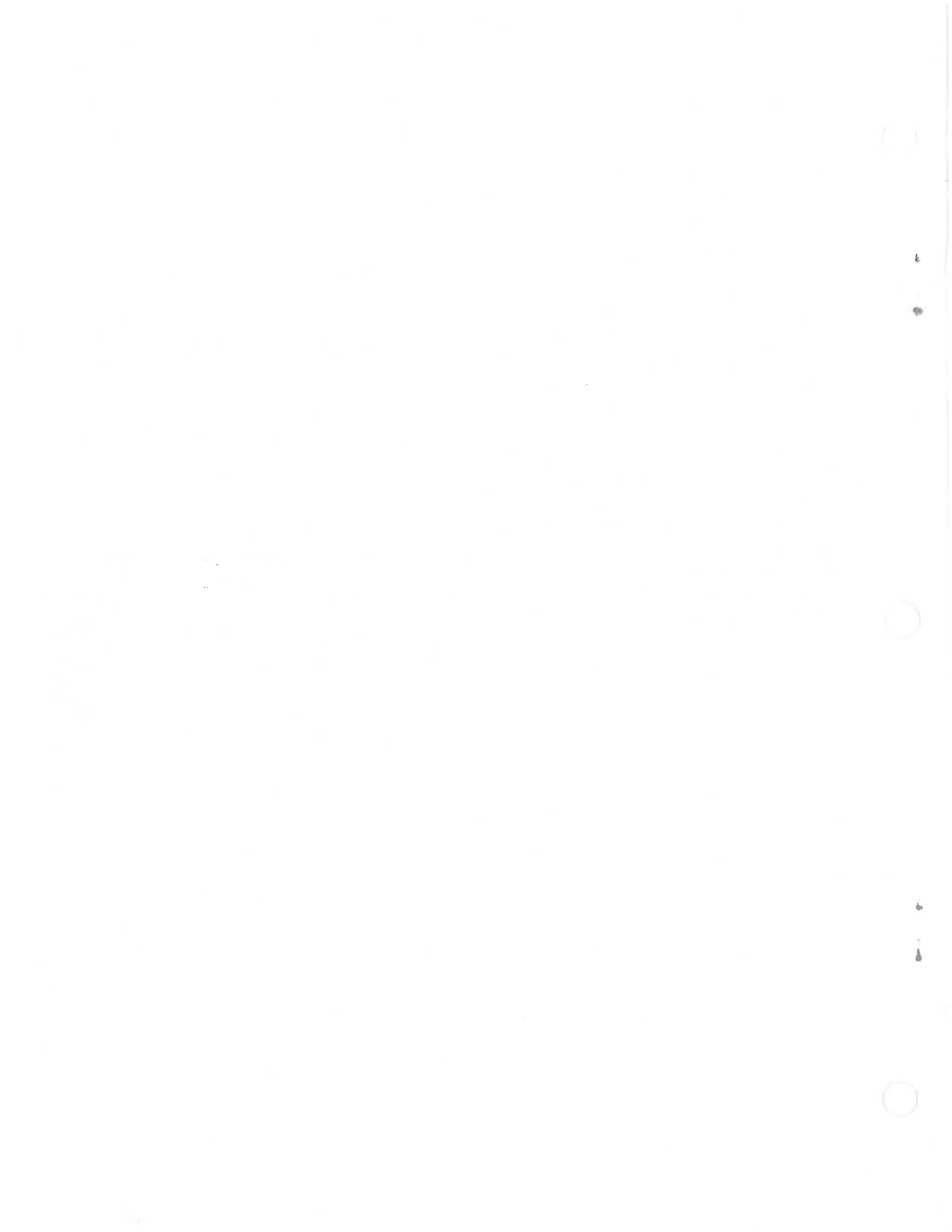







Onan Corporation  
1400 73rd Avenue N.E.  
Minneapolis, Minnesota 55432

Telephone: (612) 574-5000  
Telex: 275477  
Cable ONAN